



Micro-perforated channels

AIR CONTROL

Air Control is a specialist in products and technologies for the control and diffusion of air.

In air conditioning systems, choosing the right air diffusion system is certainly one of the key points for achieving the optimal level of comfort.

The high induction micro-perforated channels allow for rapid and comfortable uniformity of the air characteristics in the room, perfectly mixing the air introduced with that present in the room.

The range of Air Control micro-perforated channels is divided into:

STEEL Channels

STRONG STEEL

FABRIC Channels

STRONG FABRIC

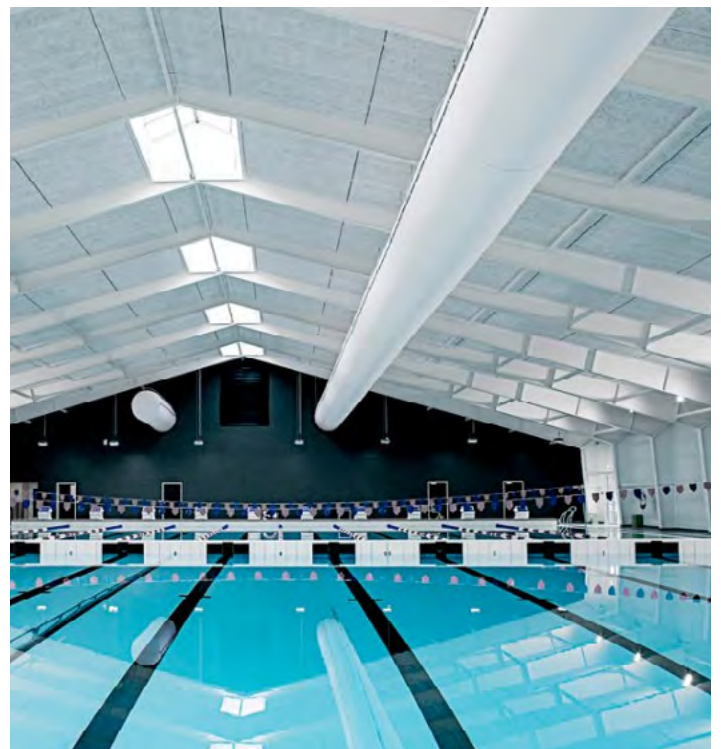

Technologies

High induction diffusers allow for rapid and comfortable uniformity of the air characteristics in the environment, perfectly mixing the air introduced with the air present. The ratio between the air moved and the air treated is called "induction ratio".

High induction is achieved thanks to a calibrated perforation calculated with dedicated software, through which it is possible to define the air throw adapted to specific needs, with the elimination of stagnation and stratification areas.

Thanks to the control of all the parameters and the homogenization of the temperatures in the environment, it is possible to obtain low speeds at human height in the entire treated area.

Inductive technology can be exploited using different materials, shapes and sections.

Installation example



Commercial indications

- Ducts over Ø 200 are supplied open (please refer to saves space and limits transport damage).
 - The open ducts are closed with the appropriate re-screws that are supplied as standard, if you need screws you must request them when ordering.
 - All galvanized ducts are supplied wrapped.
- Tie rods are not included (for steel channels).
- The cap will have the AIR CONTROL logo as standard from the attached photo, if you want the cap without the logo, you must request it when ordering.
 - The standard length of the rods is 1.25 m.
 - Delivery times are 2/3 weeks for the galvanized and pre-painted and 3/4 weeks for painted.
 - A QR code will be applied on the pallets with where you can download, in addition to the transport document, the assembly diagram.

Cap with logo



Strong Steel

High induction metal micro-perforated channels

The MICRO-PERFORATED STEEL high induction diffusers find their ideal application when the aim is to obtain the greatest possible homogeneity in the diffusion of air in the environment, without aesthetic compromises, integrating and adding value to the architectural context.

| | |
|----------------------------------|--|
| TYPE OF OPERATION | Heating, cooling, ventilation |
| INSTALLATION HEIGHT | From 3m up to 20m |
| INDUCTION RATIO | Ratio between air moved and air introduced: from 15 to 50 |
| ALLOWABLE TEMPERATURE DIFFERENCE | $T_{amb} - T_{imm} = \max 15 \text{ K}$ |
| FIELDS OF APPLICATION | Shopping centers Conference and event areas Production sites Open space offices Logistics centers All large volume environments |
| AVAILABLE SECTIONS | CIRCULAR |

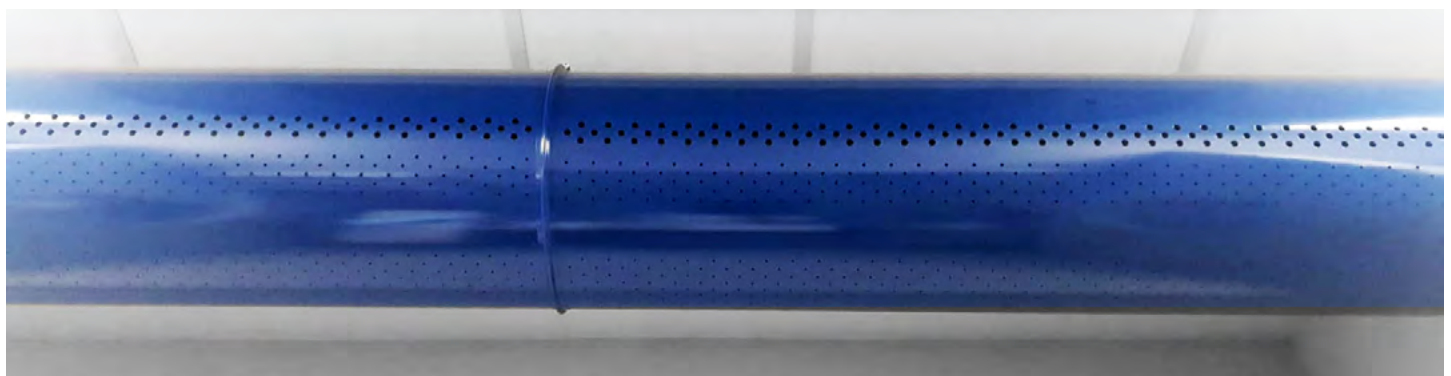

| MATERIAL | SURFACE TREATMENT | FINISH |
|--|---|--|
| Galvanized steel Product Code: ID-Ø-Z | Hot dip galvanizing | Microflower |
| Pre-painted steel Product Code: ID-Ø-P | Anti-corrosive primer and polyester paint | Aluminium grey RAL 9006 Anthracite grey RAL 7016 Black RAL 9005 White RAL 9010 Blue RAL 5010 |
| Painted steel Product Code: ID-Ø-V | Powder coating | The entire RAL CLASSIC scale |



Available sizes and pieces

Circular Section

This is the section that allows for maximum versatility, allowing the use of both semicircles for positioning the drilling.

| | LENGTH | DIAMETERS | SUPPLY |
|--|--------|--|---------------------------|
|   | 1.25 m | From 200 up to 1500 mm pre-painted Galvanized and INOX | Open with system EASY FIT |

The EASY FIT system allows for quick positioning of the modules for riveting, which is extremely easy. The preformed seats for fixing ensure perfect alignment and give great stability and rigidity to each individual module, facilitating installation across the entire range of diameters.

The non-diffusing duct sections are equipped with anti-condensation perforations, unless otherwise specifically requested.

The number of omega collars required to connect the modules is calculated for each individual order and is always included in the supplies.

Additional collars can be ordered if necessary.

Other Components

Cod. **CAP-Ø-Z/P/V**



TAPPO

Cod. **CURVE45-Ø-Z/P/V**

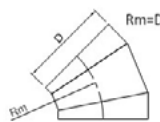

CURVA 45° - 60°

Cod. **CURVE90-Ø-Z/P/V**

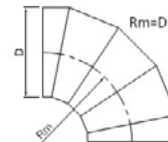

CURVA 90°

Cod. **ROSETTE-Ø-Z/P/V**

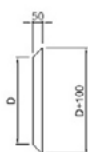

ROSONE COPRIFORO

Cod. **REDUCTION-Ø-Z/P/V**

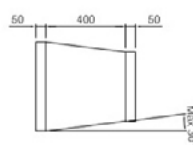

RIDUZIONE CONCENTRICA

Cod. **TEE-Ø-Z/P/V**

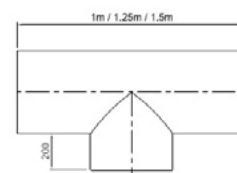

RACCORDO A TEE

All curves can be produced on request with a specific angle. Air Control produces, according to customized specifications, the connections to the ducted internal units, both in insulated version and with anti-condensation drilling.

Strong Fabric

Micro-perforated fabric channels

The MICRO-PERFORATED FABRIC high induction diffusers find their ideal application in all those creations in which the objective is the MAXIMUM possible homogeneity of the physical parameters of the air in the environment.

The great advantages that are added, thanks to the materials with which they are produced, are the extreme LIGHTNESS, the ease and SPEED of installation, the simplicity of MAINTENANCE and SANITIZATION.

They are produced with CIRCULAR and QUARTER CIRCLE sections.

The supply of textile diffusers is always complete with a standard fixing system, consisting of a galvanized steel cable, for tensioning and cross-section, and hardware for fixing and hanging.

| | |
|----------------------------------|---|
| TYPE OF OPERATION | Heating, cooling, ventilation |
| INSTALLATION HEIGHT | From 3m up to 20m |
| INDUCTION RATIO | Ratio between air moved and air introduced: from 15 to 50 |
| ALLOWABLE TEMPERATURE DIFFERENCE | $T_{amb} - T_{imm} = \max 15 K$ |
| FIELDS OF APPLICATION | Supermarkets Multipurpose structures and tensile structures Sports centres and swimming pools Production sites, Food industry Logistics centers |
| AVAILABLE SECTIONS | CIRCULAR QUARTER CIRCLE |

Fino a diametro 500 mm

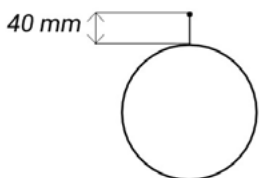

Dal diametro 500 mm

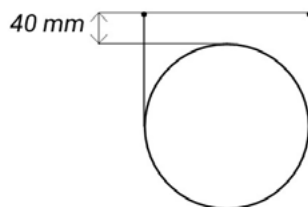











The dimensions show the standard measurements expected for the pendants, unless otherwise specifically requested.



For circular channels, unless otherwise requested, the cable required for the stretchers and the section breakers is supplied as standard. As an accessory, on request, the single or double groove aluminum profile for suspension can be supplied. For semicircular and lenticular channels, aluminum profiles are always provided, necessary for ceiling installation.

| MATERIAL | COMPOSITION AND PROPERTIES | WEIGHT | RESISTANCE TO FIRE (EN 13501-1) |
|--|---|----------------------|---------------------------------|
| POLYESTER Product code: ID-Ø-T | 75% POLYESTER 25% ACRYLIC/POLYURETHANE coating | 160 g/m ² | Euroclass B s1, d0 |
| | On request: with ANTISTATIC/ANTIBACTERIAL treatment* | | |
| | Plot Breaking load 700 N/5cm Elongation 42% | | |
| FIBER MINERAL | 88% FIBERGLASS 12% Fireproof POLYURETHANE coating | 450 g/m ² | Euroclass A1 |
| | Plot Breaking load 250 daN/5cm Elongation 0% | | |

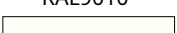
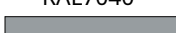
* Available only in some colors, according to quantity required

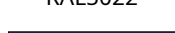
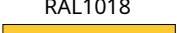
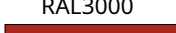
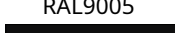
| AVAILABLE COLORS | | | | |
|------------------|--|--|---|--|
| POLYESTER | RAL9010  | RAL7040  | RAL6016  | RAL5010  |
| | RAL1018  | RAL3002  | RAL9005  | RAL2002  |
| FIBER MINERAL | RAL9010  | RAL7040  | RAL6032  | RAL5022  |
| | RAL1018  | RAL3000  | RAL9005  | |

The reference to RAL is to be understood as purely indicative.

Other Components

Cod. **CURVE-Ø-T**

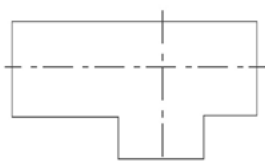

Cod. **TEE-Ø-T**

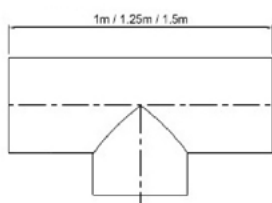

Cod. **REDUCTION-Ø-T**

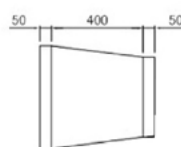

Cod. **RINGS-Ø-T**



Construction details

Fixing systems

STEEL DIFFUSERS

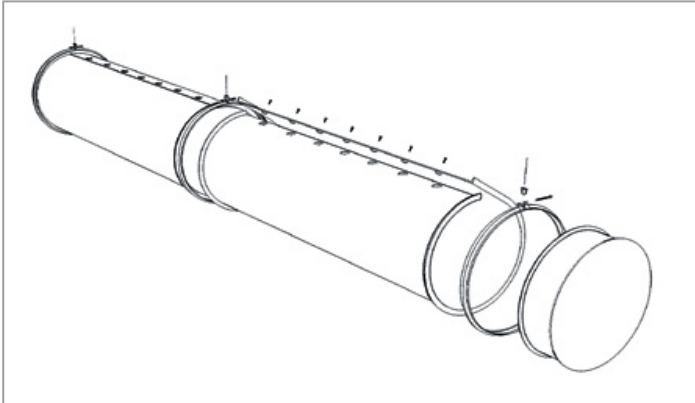

FABRIC DIFFUSERS

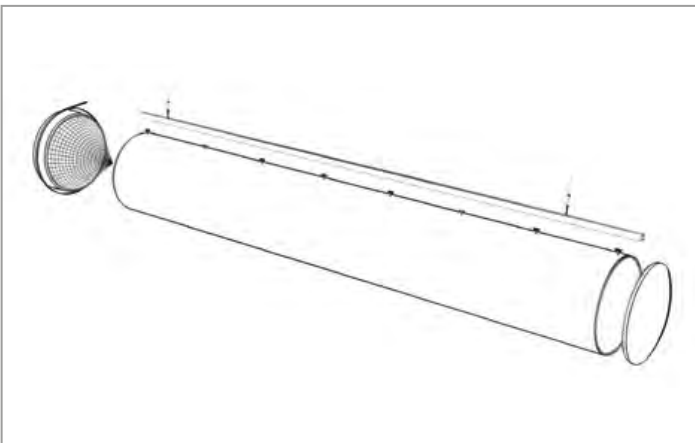
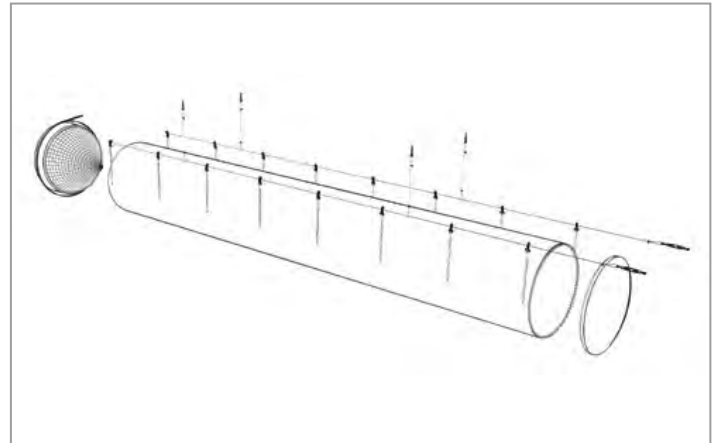
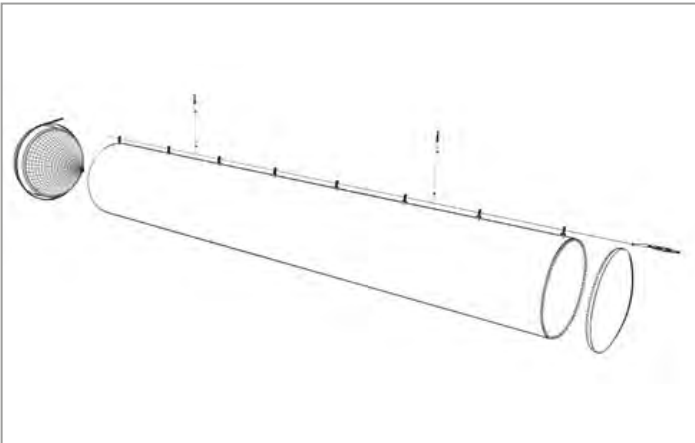

High Induction Diffusers

Sizing Wizards

Given the size of the room and the volumes/hour to be introduced, the number of diffusers must first be established. As a design criterion, consider a treated area for each side of the single diffuser, of 1.5/2 times the installation height of the duct.

Once the flow rate of each diffuser has been established, the duct is sized, choosing its diameter. Below is a summary table of the air flow rates.

|  | Minimum Air Flow | Maximum Air Flow |
|---|------------------|------------------|
| DN | m3/h | m3/h |
| 200 | 200 | 1000 |
| 250 | 400 | 1800 |
| 300 | 500 | 2300 |
| 350 | 900 | 3300 |
| 400 | 1500 | 4000 |
| 450 | 2000 | 5200 |
| 500 | 2800 | 8000 |
| 550 | 3500 | 8500 |
| 600 | 4400 | 12300 |
| 700 | 5600 | 16500 |
| 800 | 7200 | 19500 |
| 900 | 9100 | 22000 |
| 1000 | 11300 | 24000 |

Design sheet

DATA FOR INDUCTIVE SYSTEM DESIGN

| | |
|--|--|
| AIR FLOW RATE INTO THE DUCT IN m ³ /h | |
| DUCT DIAMETER | |
| USEFUL PREVALENCE IN PASCAL | |
| DUCT LENGTH | |
| ROOM HEIGHT | |
| DUCT INSTALLATION HEIGHT | |
| WIDTH OF THE INFLUENCE AREA | |
| DISTANCE BETWEEN WALL AND CENTER OF DUCT | |

AMBIENTE DA CLIMATIZZARE CON CONDOTTO MICROFORATO

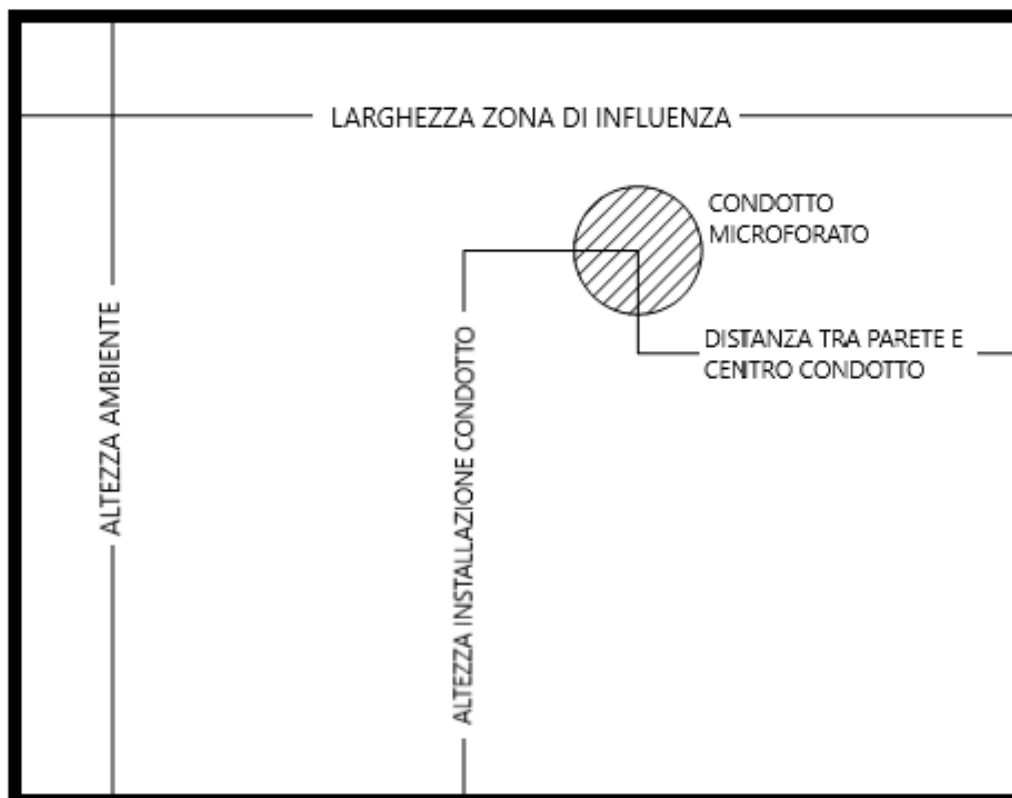

Technical data sheets - flow rate

calculation High Induction Diffusers

Sizing Wizards

Given the size of the room and the volumes/hour to be introduced, the number of diffusers must first be established. As a design criterion, consider a treated area for each side of the single diffuser, of 1.5/2 times the installation height of the duct.

Once the flow rate of each diffuser has been established, the duct can be sized by choosing its diameter using graph Fig.1.

Once the flow rate has been identified on the ordinate axis, the admissible diameters, the relative internal air velocities and the Dynamic pressure (Pd) are obtained (reported more precisely in the graph Fig.2).

Fig.1

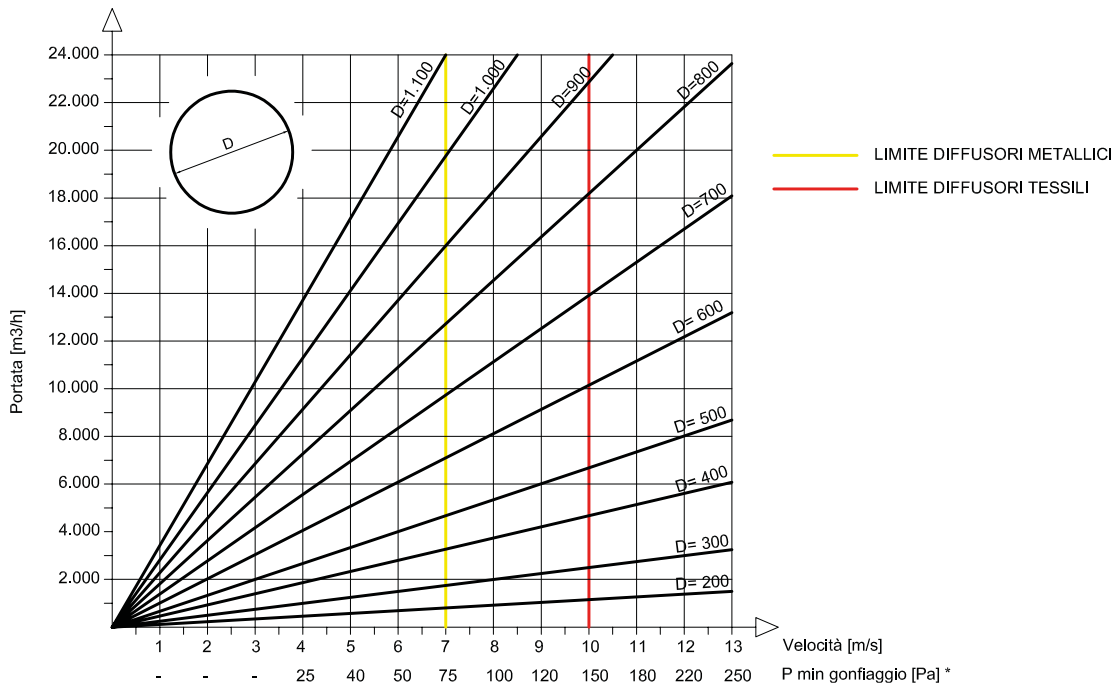
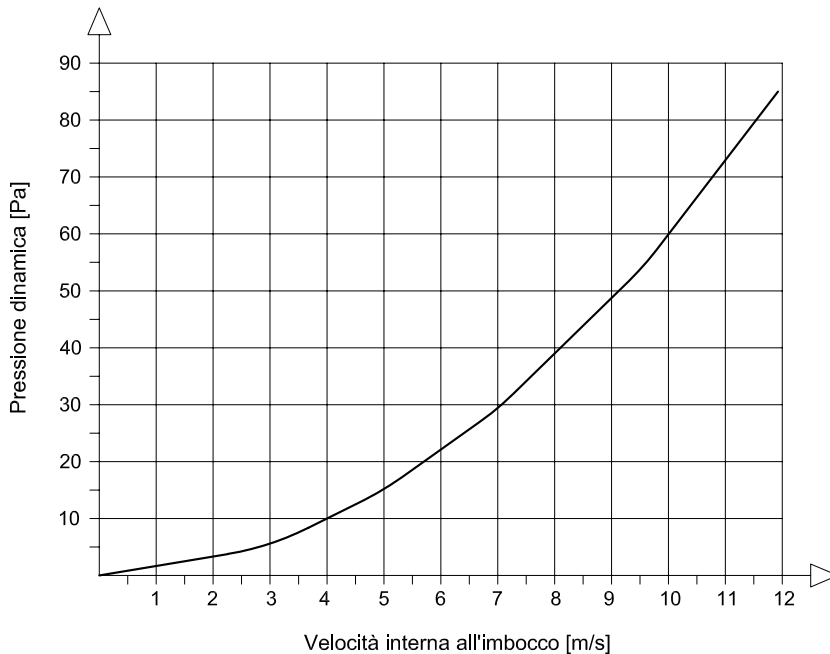

Fig.2



As highlighted in the table for textile ducts, it is advisable to maintain internal speeds of less than 10 m/s to avoid excessive turbulence, as this could cause the fabric walls of the duct to vibrate noticeably, as well as generating an unbalanced flow with unwanted axial components, which tend to carry the air introduced towards the terminal part of the room to be treated.

For metal ducts it is advisable not to exceed 7 m/s to avoid the development of noise due to friction of the air with the internal surface of the duct.

As a final step, the optimal (minimum) pressure that must be available at the entrance to the channel must be selected, using the graph Fig. 3.

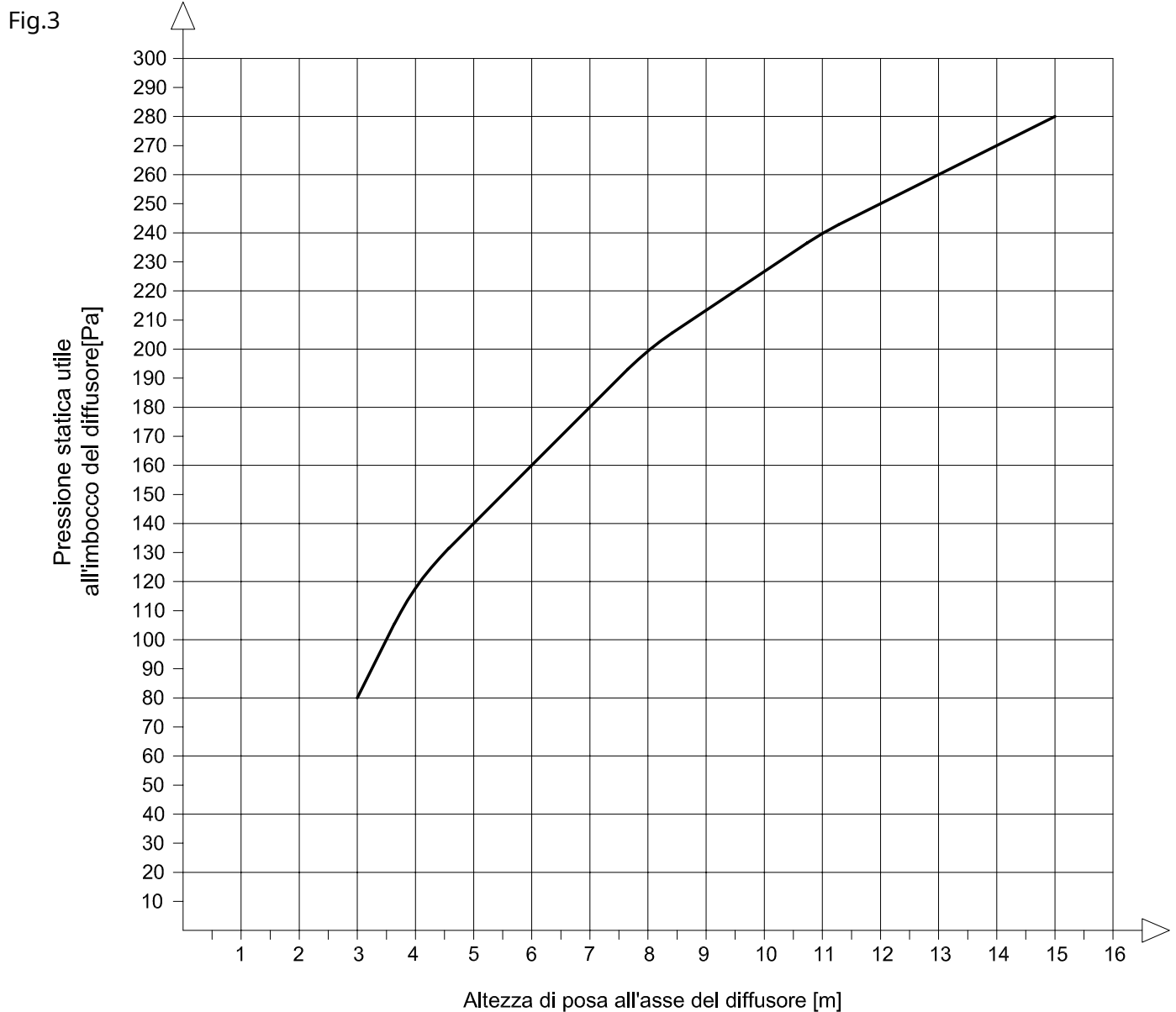

Numerical example

Sizing of a circular porous channel for cooling a room with the following characteristics:

- Length: 9 m;
- Width: 5 m;
- Height: 3 m;

To have an air recirculation of 30 Volumes/h it will therefore be necessary to have a flow rate (Q) equal to:

$$Q = 30 h^{-1} \cdot 135 m^3 = 4.050 m^3/h$$

From the table Fig.1 we obtain:

$$D = 400 mm \quad P_d = 50 Pa \quad P_{min} = 120 Pa$$

Choose a duct length of $L = 8 m$, leaving 1 m free with respect to the length of the room for connection to the ventilation unit or for its positioning.

For the lateral surface (Sl) we will have:

$$Sl = \pi D \cdot L = 10 m^2$$

The permeability (F) consequently:

$$F = \frac{Q}{Sl} = 405 \frac{m^3/h}{m^2}$$

From the table Fig. 5, for example, choose a V600 fabric with:

$$P_{st} = 60 Pa$$

And so for the final check:

$$P_t = P_{st} + P_d = 108 Pa < 120 Pa$$

$P_t > P_{min}$

The selected fabric is therefore unsuitable, so we move on to selecting one with a higher P_{st} , for example a V450:

$$P_{st} = 90 Pa$$

$$P_t = P_{st} + P_d = 140 Pa > 120 Pa$$

$P_t > P_{min}$

The selected fabric is therefore suitable; the channel will therefore have the following characteristics:

- Length: 8 m;
- Diameter: 400 mm;
- Fabric: V450;

And it will be powered by a machine set at the operating point with:

- Flow rate: 4,050 m³/h;
- Pressure: 140 Pa.

Textile Channels

Sizing Wizards

Given the dimensions of the room and the volumes/hour to be introduced, the number of diffusers is established. As a design criterion, consider a treated area, for each side of the single diffuser, of 0.5/1 times the installation height of the duct.

Once the flow rate of each diffuser has been established, the duct can be sized by choosing its diameter (graph Fig.1 page 9).

Once the flow rate has been identified on the ordinate axis, the admissible diameters, the relative internal air velocities and the Dynamic pressure (Pd) (reported more precisely in the graph Fig.2 page 9) necessary at the inlet to guarantee correct inflation of the diffuser are obtained.

As reported in the table, it is advisable to maintain internal speeds lower than 10 m/s to avoid excessive turbulence. If possible, it is advisable to select diameters with relative speeds of about 6-7 m/s since these correspond to lower Pd and Pmin values.

With the diameter obtained we move on to the calculation of the flow rate per square metre that must be spread (F), a value that is obtained through the following formula:

$$F = \frac{Q}{Sl}$$

where Q is the flow rate that will feed the channel and Sl is the lateral diffusing surface of the channel. Using graph Fig. 5, the admissible permeability values and the relative Static Pressure (Pst) necessary for diffusion are then obtained. With these, it must be verified that the total useful Pressure (Pt) is greater than the Pmin obtained when choosing the diameter, knowing that:

$$P_t = P_{st} + P_d$$

If this condition is not met, it will be necessary to choose a type of fabric corresponding to a higher Pst, until the aforementioned requirement is satisfied.

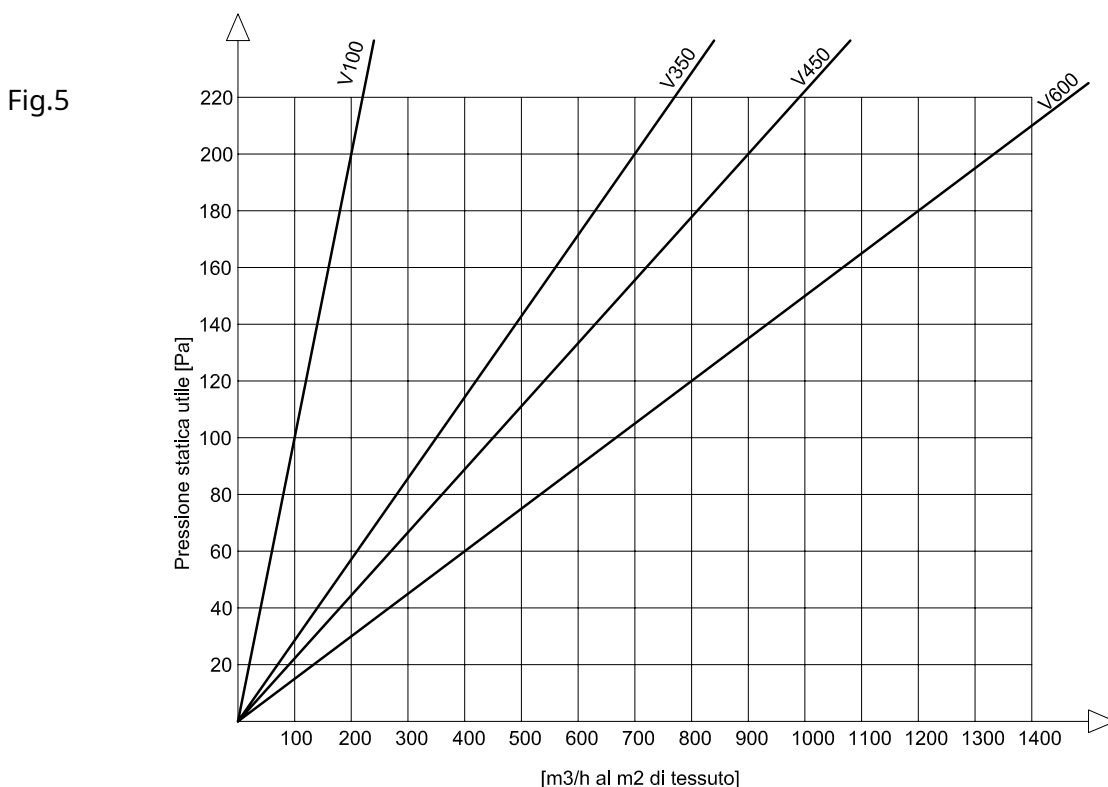

Numerical example

Sizing of a system for the treatment of an environment with the following characteristics:

- Length: 60 m;
- Width: 45 m;
- Height: 7.5 m;

To have an air recirculation of 2 volumes/h it will therefore be necessary to have a flow rate (Q) equal to:

$$Q_{tot} = 2h^{-1} \cdot (60m \cdot 45m \cdot 7,5m) = 40.500m^3/h$$

Taking the installation height (H) as 7 m, a treated area of approximately 14 m per side can be considered, therefore, two 58 m long ducts placed longitudinally (leaving 2 m of space with respect to the length of the room for connection to the ventilation unit or for its positioning) can be sufficient to treat the entire room.

Assuming that we want to treat the environment homogeneously, dividing the total flow rate by the number of channels, I obtain a flow rate for each single channel of $Q = 20,250 m^3/h$.

Let's assume we want channels with a circular section, from Fig.1 we obtain a diameter $D = 1,000 mm$ with an internal velocity of just over 7 m/s.

Finally, in Fig.3 we see that for a 7 m high channel, the pressure at the diffuser mouth must be 220 Pa.

So the broadcasting system will be structured as follows:

- Number of channels: 2pcs
- Length: 58 m
- Diameter: 1000 mm
- Installation height: 7 m
- Flow rate: $20,250 m^3/h$
- Pressure at the inlet: 220 Pa

Fig.4

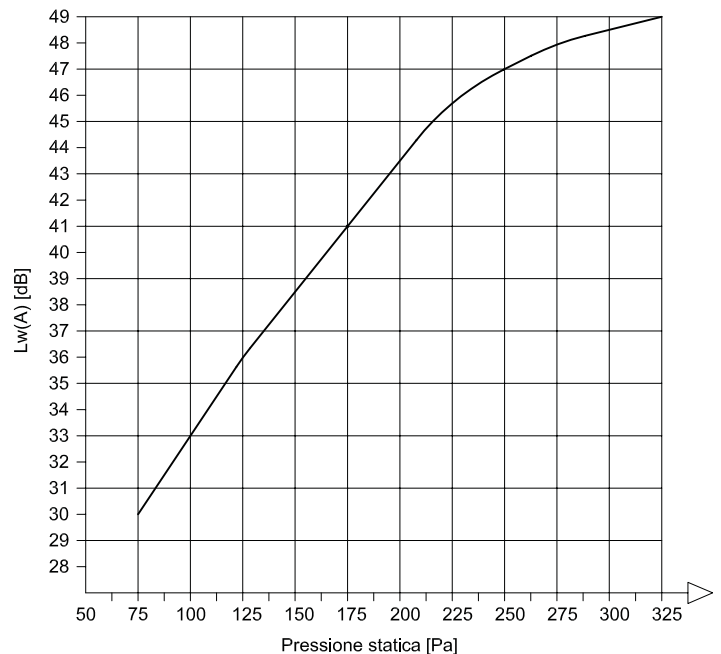

Using the graph in Fig. 4, in the case of perforated metal diffusers, it is also possible to obtain the sound power $L_w(A)$ generated by the air coming out of the perforation as the static pressure inside the channel varies.

In the case of textile channels, this last component is to be considered negligible given the strong sound-absorbing power of the fabric.

Chemical resistance of fabrics

The table below shows the resistance characteristics of the proposed fabrics to various chemical substances. Since their aggressiveness towards materials can vary based on concentration, interaction between multiple elements, temperature and other characteristics of the present atmosphere, the following table is to be considered non-exhaustive and purely indicative.

| Chemical Agent | Polyester | Fiberglass |
|----------------------------------|-----------|------------|
| Basics | | |
| Ammonia (H3N) | • | • • |
| Calcium Hydroxide (Ca(OH)2) | ••• | ••• |
| Potassium Hydroxide (KOH) | • • | • |
| Potassium Carbonate (K2 CO3) | • • | • |
| Sodium Hydroxide (NaOH) | • • | • |
| Sodium Carbonate (Na2 Co3) | ••• | • |
| Salts | | |
| Calcium Chloride (Ca Cl2) | ••• | • • |
| Ferrous Chloride (Fe Cl2 4H2O) | ••• | • |
| Sodium Acetate (C2 H4 Na O2) | ••• | • • |
| Sodium Metabisulfite (Na2 O5 S2) | ••• | ••• |
| Sodium Bromide (Na Br) | ••• | • |
| Sodium Perchlorate (NaClO4) | ••• | o |
| Sodium Cyanide (NaCN) | ••• | • • |
| Sodium Nitrate (NaNO3) | ••• | • • |
| Sodium Sulphate (Na2 SO4) | ••• | • • |
| Sodium Sulfide (Na2S) | ••• | • • |
| Zinc Chloride (Cl2 Zn) | ••• | • |
| Mineral Acids | | |
| Chromium Trioxide (Cr O3) | ••• | ••• |
| Hydrochloric Acid (HCl) | ••• | ••• |
| Hydrofluoric Acid (HF) | • • | • |
| Nitric Acid (HN O3) | ••• | ••• |
| Phosphoric Acid (HO)3 P(O) | ••• | ••• |
| Sulfuric Acid (H2 SO4) | • • | ••• |
| Organic Acids | | |
| Acetic Acid (C2 H4 O2) | ••• | ••• |
| Benzoic Acid (C7 H6 O2) | ••• | ••• |
| Phenol (C6 H6 O) | • • | • |
| Formic Acid (CH2 O2) | ••• | ••• |
| Lactic Acid (C3 H6 O3) | ••• | • • |
| Oxalic Acid (C2 H2 O4) | ••• | ••• |
| Salicylic Acid (C7 H8 O3) | ••• | • |

| Chemical Agent | Polyester | Fiberglass |
|---------------------------------|-----------|------------|
| Organic Solvents | | |
| Acetone (H3 C-CO-CH3) | ••• | ••• |
| Benzene (C6 H6) | ••• | ••• |
| Carbon Sulphide (C S2) | ••• | ••• |
| Carbon Tetrachloride (C Cl3) | ••• | ••• |
| Chloroform (CHCl3) | ••• | ••• |
| Cyclohexane (C6 H12) | ••• | ••• |
| Acetoin (C2 H6 O2) | ••• | ••• |
| Ethanol (C2 H6 O) | ••• | ••• |
| Butanol (C4 H10 O) | ••• | ••• |
| Methanol (CH4O) | ••• | ••• |
| MEK | ••• | ••• |
| Nitrogen (N) | ••• | ••• |
| Trichloroethylene (C2HCL3) | ••• | ••• |
| Toluene (C6 H5 CH.3) | ••• | ••• |
| O-Xylene (C6 H4 (CH3)2) | ••• | ••• |
| Oxidizing Agents | | |
| Calcium Bromide (Ca Br2) | • • | ••• |
| Calcium Hypochlorite (Ca(OCL)2) | ••• | ••• |
| Carbon (C) | • • | ••• |
| Fluorine (F) | • • | • |
| Hydrogen Peroxide (H2O2) | • • | ••• |
| Iodine (I) | ••• | ••• |
| Ozone (O3) | ••• | ••• |
| Potassium Chloride (KCl) | ••• | ••• |
| Sodium Chlorate (Na Cl O3) | ••• | ••• |
| Sodium Hypochlorite (Na OCl) | • • | ••• |
| Various | | |
| Acetaldehyde (H3C-CHO) | ••• | ••• |
| Ethanol (H2 C-CH2 O) | ••• | ••• |
| Glycerol (C3 H8 O3) | ••• | ••• |
| Ethylene Glycol (C2 H6 O2) | • | ••• |
| Mineral oil | ••• | ••• |
| Nitrobenzene (C6 H5 NO2) | ••• | ••• |

LEGEND:

- *Excellent resistance*
- • *Good resistance (to be verified based on the concentrations in the environment)*
- *Poor resistance*
- o *Poor resistance*

TERMS OF SALE

ORDERS

Only written orders will be accepted. AIR CONTROL will send the relevant order confirmation as soon as possible, correcting any anomalies or discrepancies and indicating the expected shipping date. In the case of particular customer needs and non-availability of all the ordered material in stock, partial fulfillments will be possible.

PAYMENT METHODS

Different conditions may be agreed upon in writing with the Commercial staff of AIR CONTROL SRL. Any unpaid due dates on the established date will result in the application of legal interest in force from that date and the payment of the related additional costs. In the event of non-compliance, AIR CONTROL reserves the right to block any orders still in progress and to request payment of the customer's total debt.

SHIPPING AND PACKING

The shipments of the material will be made in cardboard boxes, carriage paid, with charges on the invoice. For information on this matter, contact the Commercial staff of AIR CONTROL SRL. The material travels at the risk and peril of the customer. Any special packaging requested directly by the Customer will be accounted for separately.

CANCELLATION OF ORDERS

Any order cancellations will be possible only if previously approved by the AIR CONTROL Sales Management. All related costs are the responsibility of the customer.

DEFECTIVE MATERIAL UNDER WARRANTY

AIR CONTROL will deliver/ship material under warranty for replacement only after prior receipt of the returned goods, checked and verified in the company, previously authorized. Otherwise the following will apply. Upon receipt of the 'returns' form, duly completed and signed, in the event of a request for replacement under warranty of material not yet received and verified by AIR CONTROL, the goods will be delivered/shipped, with regular issuance of a sales document and relative invoice.

Upon return of the replaced material, to be received by AIR CONTROL, within 15 days from the date of the transport document mentioned in the previous point, the relative invoice will be totally cancelled with the issue of a credit note, after verification of the actual defect/integrity of the material. The faulty goods will be collected at the expense of AIR CONTROL, upon notification of the goods ready by the customer, then proceeding with the appropriate checks of defects in the company, to provide for any cancellation.

After 15 days from the date of the delivery note of the material requested as a replacement, the related returns will no longer be accepted and payment of the corresponding invoice will still be required, considering it subject to the normal sales policy in progress.

NON-CONFORMITY ATTRIBUTABLE TO THE CUSTOMER

The customer has 8 days from the date of delivery to return the material. Authorization for the return occurs after sending, by email, the request form duly completed and stamped by AIR CONTROL. All transport costs in suitable packaging are the responsibility of the Customer and acceptance of the return does not imply the cancellation of the items in the invoice. The returned material will be canceled only if it is in perfect condition and functioning, AIR CONTROL will retain 20% of the total of the relative credit note, to offset the management costs. Returns will not be accepted for out-of-catalogue material, special dimensions, made in Pal and without the original box, except in special cases to be agreed with the management. Request forms not duly completed will not be considered valid. The transport of any replacement material is the responsibility of the customer.

WARRANTY CONDITIONS

AIR CONTROL products are guaranteed for two years on any manufacturing defect. After 10 days from the delivery date, complaints will be accepted only for problems related to the defectiveness of the components.

SPECIAL MEASURES

For special sizes the price of the next higher standard size will be applied and returns will not be accepted under any circumstances. Consult AIR CONTROL Sales staff for any delivery times and availability.

DISPUTE RESOLUTION

For any dispute, of any type or nature, arising directly or indirectly from the sale of AIR CONTROL material, products or services, they will be subject to Italian law and the competent court will be that of Milan (Italy). The customer declares to accept all the conditions set out by signing the order.

